

美国标准锥管螺纹螺纹和直螺纹尺寸

NPT尺寸

NPT尺寸	每英寸螺纹数	尺寸“A” (英寸)	尺寸“B” (英寸)
1/16	27	0.312	0.261
1/8	27	0.405	0.264
1/4	18	0.540	0.402
3/8	18	0.675	0.408
1/2	14	0.840	0.534
3/4	14	1.050	0.546
1	11 1/2	1.315	0.683
1 1/4	11 1/2	1.660	0.707

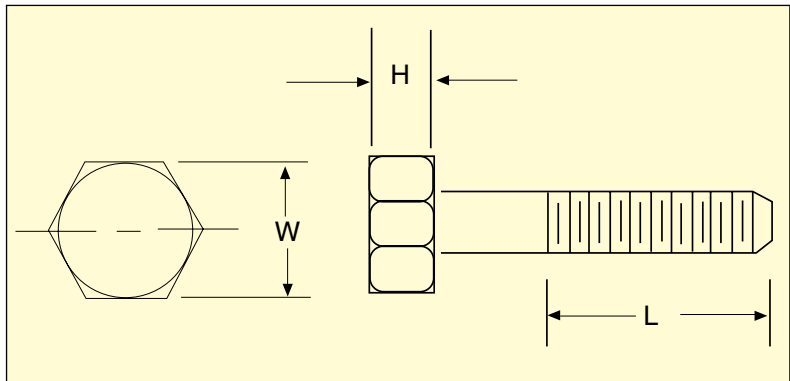
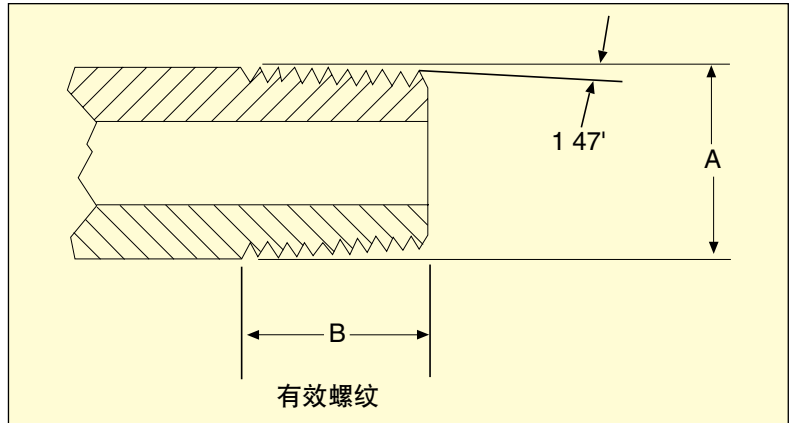

直螺纹尺寸

标称螺纹尺寸	每英寸螺纹数		大口径	W	H	L
	粗(UNC)	细(UNF)				
0	—	80	0.0600			
1	64	72	0.0730			
2	56	64	0.0860			
3	48	56	0.0990			
4	40	48	0.1120			
5	40	44	0.1250			
6	32	40	0.1380			
8	32	36	0.1640			
10	24	32	0.1900			
12	24	28	0.2160			
1/4	20	28	0.2500	7/16	1 1/64	0.750
5/16	18	24	0.3125	1/2	7/32	0.875
3/8	16	24	0.3750	9/16	1/4	1.000
7/16	14	20	0.4375	5/8	19/64	1.125
1/2	13	20	0.5000	3/4	1 1/32	1.250
9/16	12	18	0.5625	13/16	3/8	1.375
5/8	11	18	0.6250	15/16	27/64	1500
3/4	10	16	0.7500	1 1/8	1/2	1.750
7/8	9	14	0.8750	1 1/16	37/64	2.000
1	8	12	1.0000	1 1/2	43/64	2.250
1 1/8	7	12	1.1250	1 11/16	3/4	2.500
1 1/4	7	12	1.2500	1 7/8	27/32	2.750
1 3/8	6	12	1.3750	2 1/16	29/32	3.000
1 1/2	6	12	1.5000	2 1/4	1	3.250

